

Manufacturing Notebook

<https://www.nke.co.jp/>

# Product digest

**NKE**

Let's  
Humanized Automation



Humanized Automation Idea book

Since 1968 ✨Inspiration+class Name: SUTOROBO KUN

We can create your own value with our knowledge of various unit.

+ x = ∞  
**Modular Design**

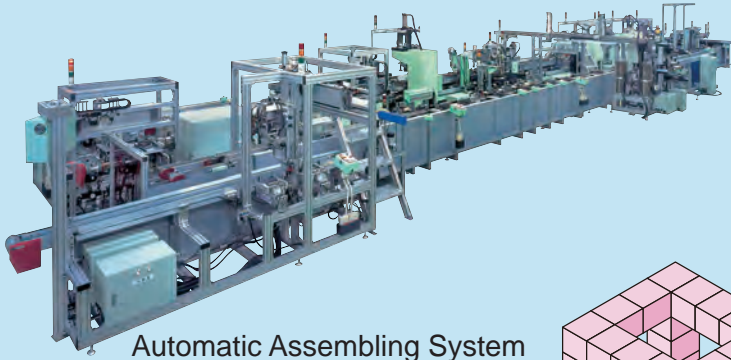

Automatic Assembling System

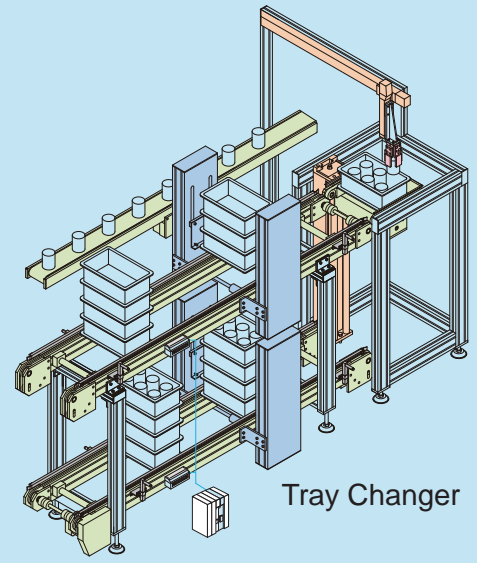

Tray Changer

We offer automation systems by combining the modules. And you can shorten the delivery date by modularization.

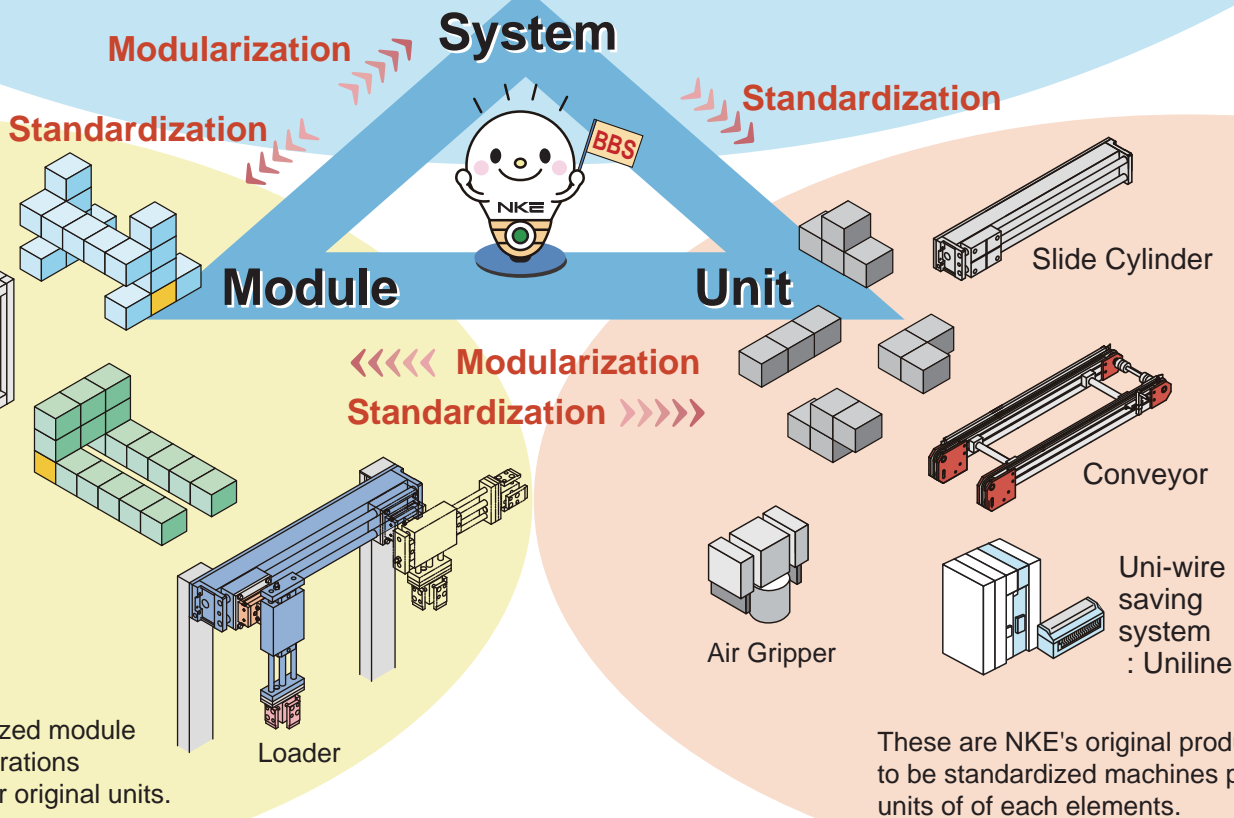
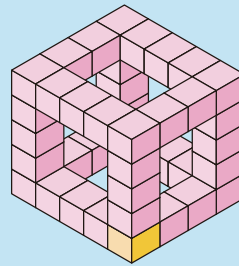

This is standardized module systems per operations by combining our original units.

These are NKE's original products to be standardized machines per units of of each elements.

We, NKE Corporation, have cultivated the various automation knowledge to maximize our customer's productivity for a long time. We respond to our customer's request with automation engineering to maximize productivity with low cost. Our company aims to be the special automation company. And we solve our customer's problem with our original products and automation engineering power to design the automation systems from zero.

Optimize the product supply that has difficulties for making efficient.

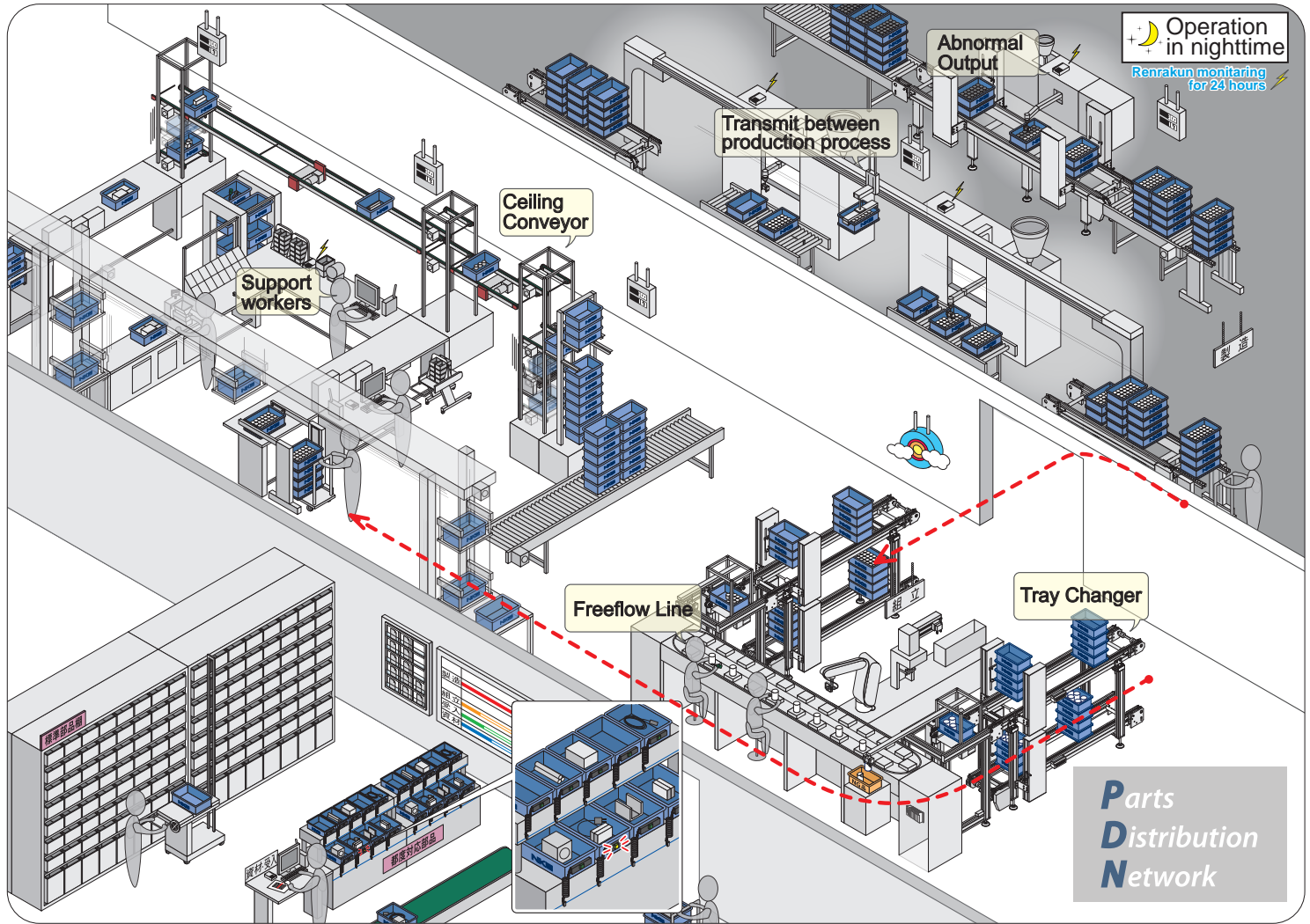

## BBS

### Block Building System

This is one of our solutions for totally optimizing your production systems. BBS realizes thorough improvement and informational advancement for production facilities corresponded to customer's need and makes your production systems more efficient and integrated.

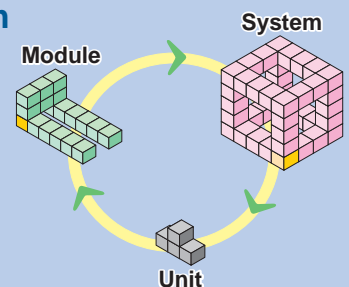

## PDN

### Parts Distribution Network

This network is to optimize part's supply, wait and transmission, and to work more safely and comfortable for the operator. This is the comfortable system to support workers aiming to reduce their burdens and mistakes, not only to seek the automation and efficiency as usual.

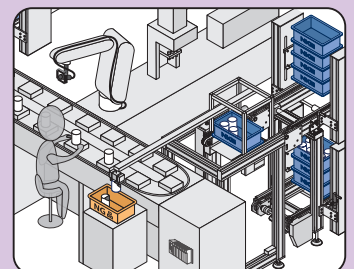

## Rotary Actuators with many series

### NKE Parts Handling Machines

#### Turn over the parts

Enable to combine various ways depending on work's weight.

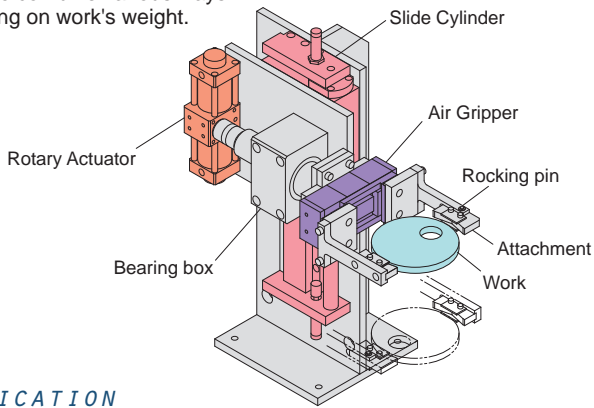

APPLICATION

#### Can use for a long time by overhauling

##### Reparable

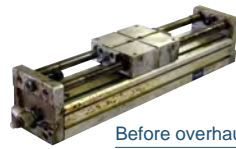

Before overhauling  
Sent back to our factory like this.



After overhauling  
Move smoothly like new one.

We are not only to dismantle and clean the machines, but also to check inner and outer parts and to make like new ones.



#### Parallel Type

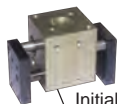

Initial model  
Long selling product

[New Product]  
Air Gripper with  
lightness and high power



#### Lever Type



#### Special Type



180° open



#### Pick & Place

##### Small Type

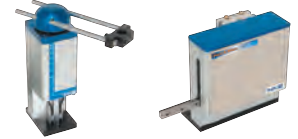

##### High Accuracy Type

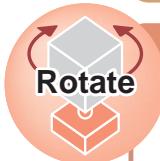

#### Rotary Actuator

##### Low Power Type

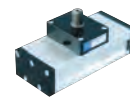

##### High Power Type



#### Slide Cylinder

##### Short Stroke



##### Middle Stroke



##### Long Stroke

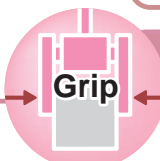
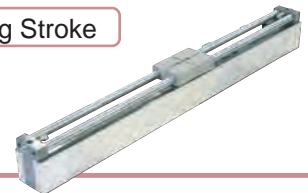

#### Air Gripper



For bottle's use

[Example]

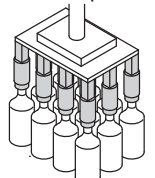

# Conveyor Equipment

Eco friendly product



Reparable

Conveyor and surrounding equipments consist of transmitting parts

## NKE Conveyor Equipment

### Turn on the conveyor and divide works

This application is to turn on the conveyor and divide works. Good quality products are turned on and transferred to the next conveyor horizontally one by one but defective ones are discharged.

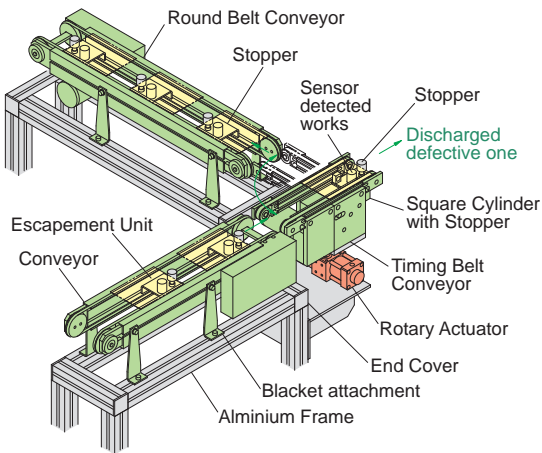

APPLICATION

### Pile up and down containers on conveyor

This application is to pile up and down containers on conveyor

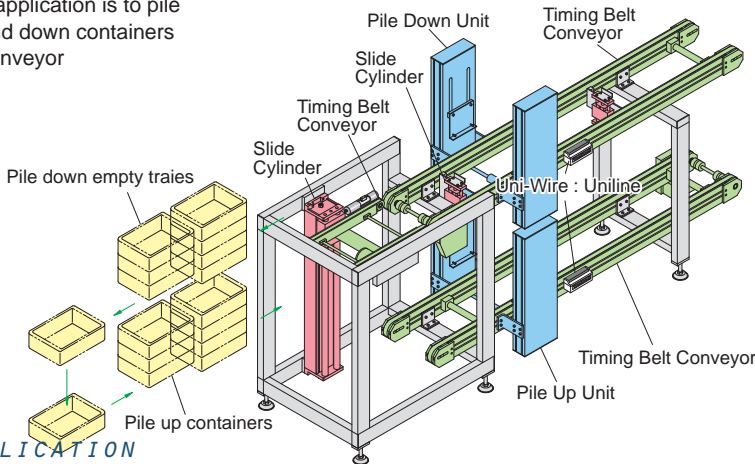

APPLICATION

Stack

### Tray Changer

Middle-size Flexstack



Large-size Flexstack



Stop

### Escapment Unit

Stopper Unit



Escapment unit



Transfer

### Conveyor

Flat Belt Conveyor

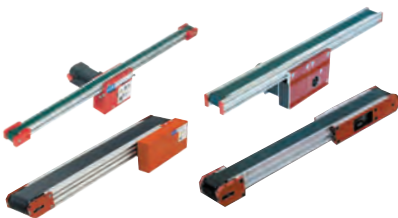
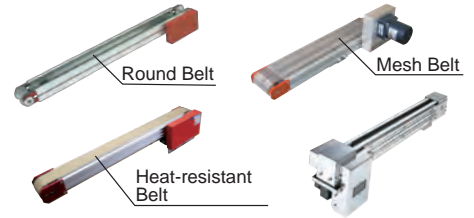

Table-top Chain Conveyor



Special Belt Conveyor



Timing Belt Conveyor

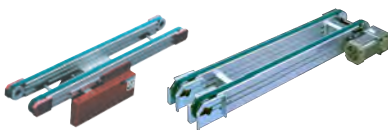

Plastic Chain Conveyor



Roller Chain Conveyor



Special Conveyor



Simple and flexibly construct Uni-Wire system that meets the factory demand

## NKE Wire-Saving Instruments

## UNILINE

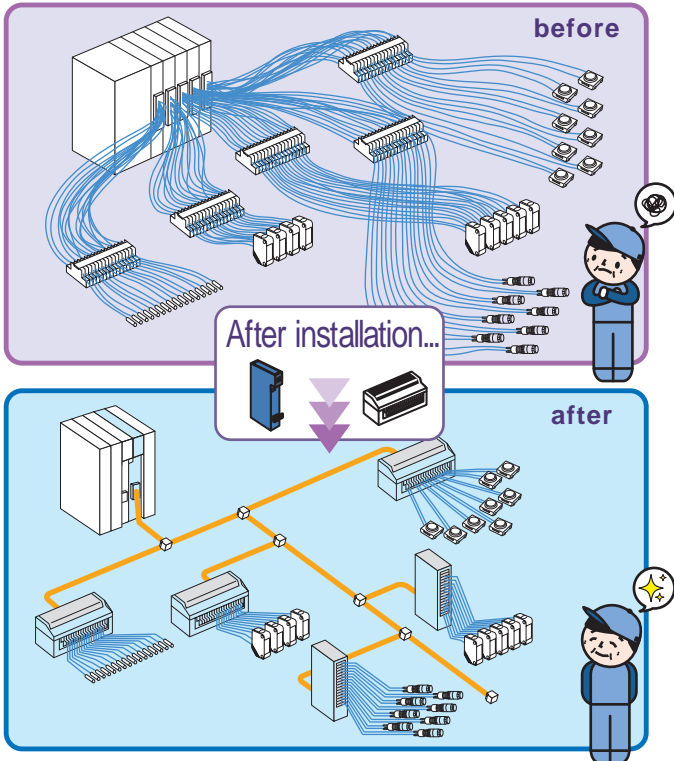

**Controllers Interface card**

- <PLC connections interface>
  - Mitsubishi Electric Corp. Qseries
  - Omron Corp. C200H/CS1/CJ1
  - Yokogawa Electric Corp. FA-M3
  - Toshiba Corp. S2T/S2E
- <Gateway for Upper network>
  - CC-Link, DeviceNet
- <Interface Card for Computer>
  - PCI buses

**Control Units**

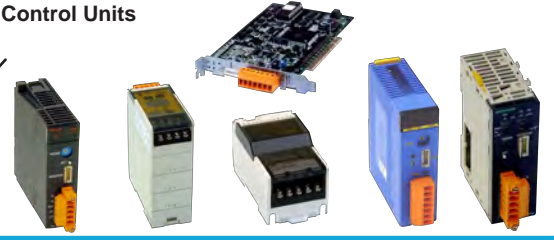

**Terminal Unit**

**Terminal Units**

**Terminal Block Type**

**Analog Type**



**Connector Type**

e-con, Mil, Fujitsu, etc.

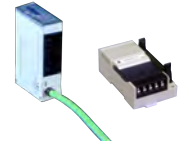

**Low count I/O Type**



**Trolley Buffer Unit**



**Optical Fiber Transmission Unit**



**Data Transfer Unit**



**Real Time Monitor**



APPLICATION

**Automobile Product Line**



It's suitable for Wire-saving Instruments of handling machines that attach the tip of welding robot. It's highly valued easy maintenance, anti-noise performance and tough wire for operation parts, because of less wiring.

**Trolley**

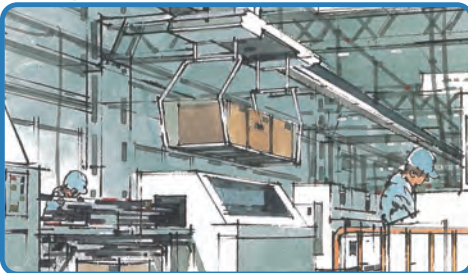

Trolley line can be used for transmission line, because Uniline doesn't need the specified cables. You can reduce large number of curtain rail wires, weight and trouble for the snapping of wires.

Uniline have many records for custom-made orders. It enables to use in various ways: You prepare the compact units loaded relay for cutting electric parts with mass capacity in equipments, connect controller units with compressor and control while measuring the demand value. Uniline can transfer up to 1km with two cores of communication line and wiring method is free layout of T-Junction or multidrop communication system. It can flexible response, no limit in FA that can use general cab-tire cable, no need of special cable.

**Uniline is very useful, even if except FA**

Electric equipments in supermarket or electric sales shop



Uniline is to simplify the complicated electric wires in stores and is useful as demand control systems. And more, it generates efficiency in one-to-N communication and deals freely with control of light or air condition.

## Can make IoT system easily with Renrakun, Just as it is your own equipment

Simple and automatically report by e-mail



Get the information soon that you wants to know

Renrakun is the information terminal units that enable to get e-mail automatically via internet. You don't need to change your equipment largely for installation. Please prepare input machines to send abnormal signals and LAN conditions with Internet, depending on you. You can make simply and speedy automatic report system, and get the abnormal output anytime and anywhere.

Can operate Renrakun from remote area  
Installation of command mail

You can operate Renrakun's status controls and can Input or Output by e-mail from remote area.

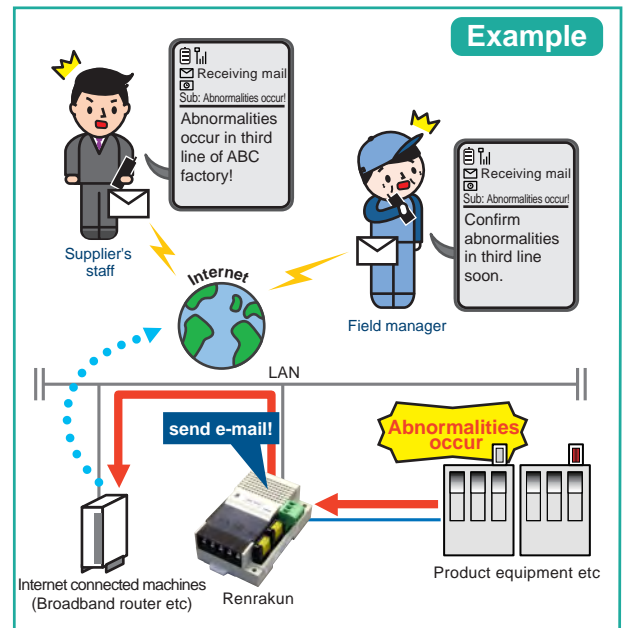

Renrakun can do like this !

- Case1** can confirm Renrakun's status by e-mail
- Case2** can operate machines connected with Renrakun by e-mail
- Case3** can start or stop monitoring by e-mail

**Confirm the status from remote area**

**Case1**

Check!!

Does any problems happen?

No problems!

**Switch ON from remote area**

**Case2**

ZUKYUUN!

Certainly!

Let's operate alarms and rumps.

**Change the mode from remote area**

**Case3**

Leave it to me!

START!

Let's start monitoring after closing the factory's doors.



### Renrakun has many varieties

input

Single operation with only input and affordable!

Renrakun in general

input

output

Can setup easily with output operation!

Renrakun in general with output

input

wireless version

Can connect many units with wireless Lan cables!

Renrakun with wireless Lan

input

with keep alive packet

Can confirm communication with keep alive packet!

Renrakun in general with keep alive packet

output

x-8

Can control many units with one Renrakun!

Eight-point Input / Output Renrakun

Renrakun

Can control with showing graphically of analog value!

Analog Renrakun

output

+

Add output operation with Analog Renrakun!

Analog Renrakun with output

can use for product control display!

Can count number of products or defective products!

Counter Renrakun

目標	100
実績	6
残数	94

Recommend!!

Make surveillance of processor or machines!

Operation Surveillance Renrakun

Please call us anyway if you want to know from programming or planning for equipment to supporting after system installation.

Free dial AM9:00~PM5:00 (except weekend and holiday)

 **0120-51-5651**  
Parts Handling Machines, Conveyors, Cell Machines

 **0120-77-2018**  
Uniline, Network machines

 **Caution**

- Please read surely the manual attached to machines when you use.
- Please use the machines within the conditions and specifications indicated in the catalogue and manuals.

Please ask for the master catalogue of NKE products



**NKE CORPORATION**

(NAKAMURA KIKI ENGINEERING CO., LTD)

<https://www.nke.co.jp/>

**Head Office and Factory**

HISHIKAWA-CHO 366-1, HAZUKASHI, FUSHIMI-KU, KYOTO  
TEL:075-924-0653 FAX:075-924-4653

**SAITAMA BRANCH**

MARUGASAKI-CHO, MINUMA-KU, SAITAMA-CITY, SAITAMA  
TEL:048-797-9671 FAX:048-797-9672

**NAGOYA BRANCH**

2-13-22, ISEYAMA, NAKA-KU, NAGOYA-CITY, NAGOYA  
TEL:052-322-3481 FAX:052-322-3483

**KYOTO BRANCH**

HISHIKAWA-CHO 366-1, HAZUKASHI, FUSHIMI-KU, KYOTO  
TEL:075-924-3293 FAX:075-924-3290

